

PROBES

DUAL NEUTRON

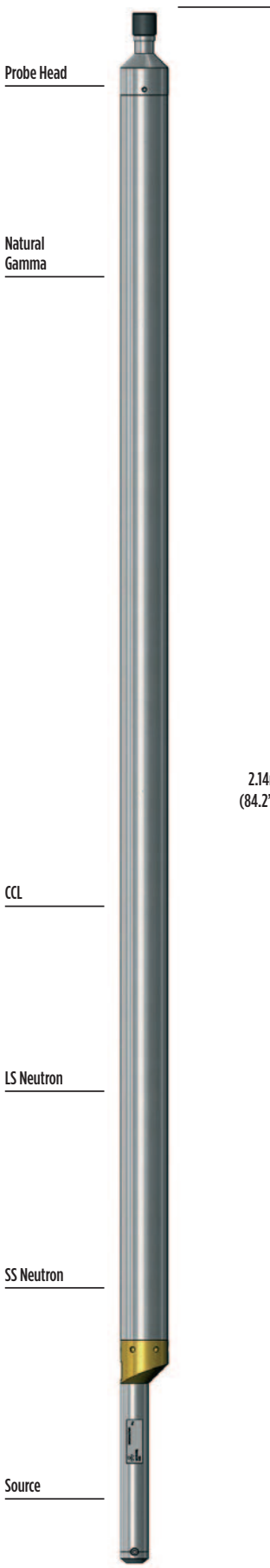

The Dual Neutron probe provides a calibrated borehole-compensated neutron porosity measurement in mud-filled open holes.

It is the probe of choice for quantitative formation-fluid studies.

A single-detector neutron probe is also available for qualitative porosity logging under most borehole conditions including through steel or plastic casing and drill-pipe.

Principle of Measurement:

The Dual Neutron measurement uses two ³He proportional detectors and a detachable, sealed ²⁴¹Am-Be neutron source. Fast neutrons emitted by the source are scattered and slowed to thermal levels, principally by hydrogen in the formation. The ratio of the neutron flux reaching the near and far detectors depends on the hydrogen index and porosity. Use of dual detectors and a ratio method provides a porosity measurement compensated for borehole diameter but not independent of it.

SPECIFICATION:

Features

- Real-time porosity measurement
- Compensation for borehole diameter

Measurements

- Compensated porosity
- Neutron (raw counts)
- Natural gamma
- Option: Casing-collar locator (CCL)

Applications

Minerals / Water / Engineering

- Lithology identification
- Location of aquifer and aquitard
- Fracture analysis in coals
- Correlation between open and cased-hole logs
- Strata correlation between wells

Operating Conditions

- Borehole type: open/cased, water-filled
- Centralisation: ex-centralised with bowspring
- Recommended Logging Speed: 4m/min

Specifications

- Diameter: 65mm
- Length: 2.14m
- Weight: 19.5kg
- Temperature: 0-70°C (0-125°C optional)
- Max. pressure: 20MPa
- Range: 15 to 45% Limestone Porosity Units (LPU)

Part Numbers

- 1002029 Dual Neutron probe with natural gamma
- 1002030 - includes CCL

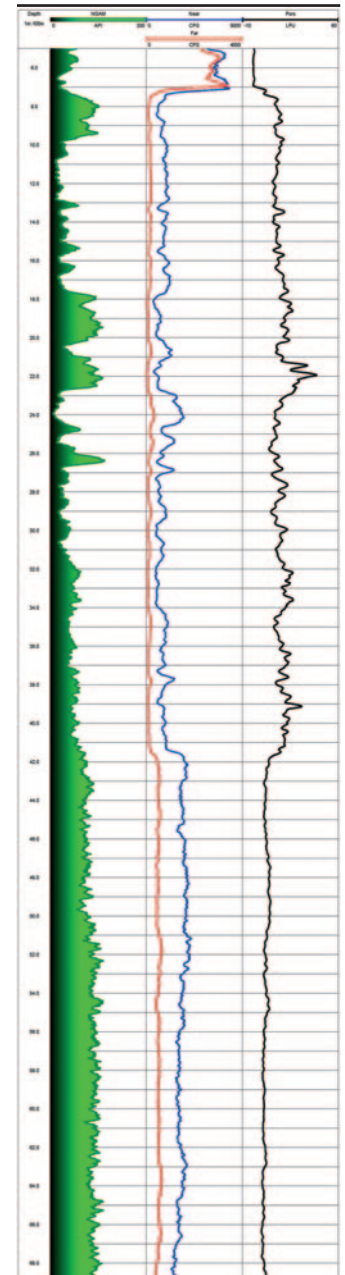

Example of logging data

▶ [CLICK HERE FOR ENQUIRY FORM](#)

Dual Neutron Probe